



Standard Test Method for Determining the Rate of Air Leakage Through Exterior Windows, Curtain Walls, and Doors Under Specified Pressure and Temperature Differences Across the Specimen¹

This standard is issued under the fixed designation E1424; the number immediately following the designation indicates the year of original adoption or, in the case of revision, the year of last revision. A number in parentheses indicates the year of last reapproval. A superscript epsilon (ϵ) indicates an editorial change since the last revision or reapproval.

1. Scope

1.1 This test method provides a standard laboratory procedure for determining the air leakage rates of exterior windows, curtain walls, and doors under specified differential air temperature and pressure conditions across the specimen.

1.2 Specified temperature and pressure conditions are representative of those that may be encountered at the exterior thermal envelope of buildings, excluding the effects of heat buildup due to solar radiation.

1.3 This laboratory procedure is applicable to exterior windows, curtain walls, and doors and is intended to measure only such leakage associated with the assembly and not the installation; however, the test method can be adapted for the latter purpose.

1.4 This is a laboratory procedure for testing at differential temperature conditions. Persons interested in a laboratory test at ambient conditions should reference Test Method E283. Persons interested in a field test on installed windows and doors should reference Test Method E783.

1.5 Persons using this procedure should be knowledgeable in the areas of heat transfer, fluid mechanics, and instrumentation practices, and shall have a general understanding of fenestration products and components.

1.6 The values stated in SI units are to be regarded as standard. The inch-pound units given in parenthesis are provided for information only.

1.7 *This standard does not purport to address all of the safety concerns, if any, associated with its use. It is the responsibility of the user of this standard to establish appropriate safety and health practices and determine the applica-*

bility of regulatory limitations prior to use. For specific hazard statements, see Section 7.

2. Referenced Documents

2.1 ASTM Standards:²

E283 Test Method for Determining Rate of Air Leakage Through Exterior Windows, Curtain Walls, and Doors Under Specified Pressure Differences Across the Specimen

E631 Terminology of Building Constructions

E783 Test Method for Field Measurement of Air Leakage Through Installed Exterior Windows and Doors

3. Terminology

3.1 *Definitions*—Terms used in this test method are defined in Terminology E631.

3.2 *Definitions of Terms Specific to This Standard:*

3.2.1 *air leakage rate (q_A or q_L)*—the air leakage per unit of specimen area (A) or per unit length of operable crack perimeter (L), expressed as $\text{m}^3/\text{s}\cdot\text{m}^2$ ($\text{ft}^3/\text{min}\cdot\text{ft}^2$) or $\text{m}^3/\text{s}\cdot\text{m}$ ($\text{ft}^3/\text{min}\cdot\text{ft}$).

3.2.2 *extraneous air leakage (Q_e)*—the volume of air flowing per unit of time through the test chamber and test apparatus, exclusive of the air flowing through the test specimen, under a test pressure difference and test temperature difference, converted to standard conditions, expressed in m^3/s (ft^3/min).

3.2.2.1 *Discussion*—Extraneous leakage is the sum of all leakage other than that intended to be measured by the test.

3.2.3 *specimen air leakage (Q_s)*—the volume of air flowing per unit of time through the specimen under a test pressure difference and test temperature difference, converted to standard conditions, expressed in m^3/s (ft^3/min).

¹ This test method is under the jurisdiction of ASTM Committee E06 on Performance of Buildings and is the direct responsibility of Subcommittee E06.51 on Performance of Windows, Doors, Skylights and Curtain Walls.

Current edition approved Oct. 1, 2016. Published October 2016. Originally approved in 1991. Last previous edition approved in 2008 as E1424 – 91 (2008). DOI: 10.1520/E1424-91R16.

² For referenced ASTM standards, visit the ASTM website, www.astm.org, or contact ASTM Customer Service at service@astm.org. For *Annual Book of ASTM Standards* volume information, refer to the standard's Document Summary page on the ASTM website.

3.2.4 *specimen area (A)*—the area determined by the overall dimensions of the frame that fits into the rough opening, expressed as m^2 (ft^2).

3.2.5 *test mask assembly*—a wall construction that surrounds and supports the test specimen.

3.2.6 *test pressure differences*—the specified differential static air pressure across the specimen, expressed in PA (lbf/ft^2).

3.2.7 *test temperature difference*—the specified difference in temperature across the test specimen, expressed as a set of room-side and weather-side temperatures, in $^{\circ}C$ ($^{\circ}F$).

3.2.8 *total air flow (Q_t)*—the volume of air flowing per unit of time through the test chamber and test apparatus, inclusive of the air flowing through the test specimen, under a test pressure difference and test temperature difference, converted to standard conditions, expressed in m^3/s (ft^3/min).

3.2.9 *unit length of operable crack perimeter (L)*—the sum of all perimeters of operable ventilators, sash, or doors contained in the test specimen, based on the overall dimensions of such parts, expressed as m (ft). Where two such operable parts meet, the two adjacent lengths of perimeter shall be counted as only one length.

4. Summary of Test Method

4.1 The procedure consists of sealing a specimen into or against a chamber capable of maintaining a specified air temperature differential across the specimen. When the specimen has been conditioned for a specified period of time, air is supplied to, or exhausted from, the chamber at a rate required to maintain the specified test pressure difference across the specimen. The resultant air flow through the specimen is then measured.

5. Significance and Use

5.1 The exterior building envelope and its components (for example, windows and doors) separate the interior conditioned spaces from exterior environmental factors such as heat, cold, rain, wind, noise dust, etc. Building materials and components can expand or contract to varying degrees, depending on seasonal and diurnal exterior ambient air temperatures. Fluctuations in the ambient air temperatures can alter the sealing characteristics of windows, curtain walls, and doors by changing weather seal compression ratios. Thermal expansion or contraction of framing materials coupled with thermal blowing due to temperature gradients through the product, and alterations in the effective leakage areas due to weather seal shrinkage and compression set, can also significantly alter the air leakage rates of these products in field service applications. Air leakage tests performed using Test Method E283 (a laboratory air leakage test performed at ambient temperature conditions) will not account accurately for changes in air leakage rates that may occur from dimensional changes in fenestration systems, materials, and components.

5.2 It is recommended that test specifiers consult the manufacturer for recommended test temperature extremes.

5.3 This procedure provides a means for evaluating air leakage rates of fenestration systems under various temperature

and pressure conditions and air flow directions. It is also applicable for use in evaluating the efficiency of weather sealing products in fenestration systems. All air flow rates are converted to standard conditions to provide a means of comparison between measurements made at different ambient air temperature and pressure conditions.

5.4 Air leakage rates are sometimes used for comparison purposes. Such comparisons may not be valid unless the components being tested and compared are of essentially the same size, configuration, and design.

6. Apparatus

6.1 The description of the apparatus in this section is general. Any suitable arrangement of equipment capable of maintaining the required test tolerances is permitted.

6.1.1 *Test Chamber*—A well sealed box, wall, or other apparatus into or against which the specimen is mounted and secured for testing. An air supply shall be provided to allow a positive or negative pressure differential to be applied across the specimen without significant extraneous losses. The chamber should also be constructed of materials that have good resistance to heat flow. The chamber shall be capable of withstanding the differential test pressures and temperatures that may be encountered in this procedure. At least one static air pressure tap shall be provided on each side of the specimen to measure the test pressure differences. The pressure tap shall be located in an area of the chamber in which pressure readings will not be affected by any supply air or air conditioning fans. The air supply to the chamber shall be located in an area in which it does not directly impinge upon the test specimen. A schematic is given in Fig. 1.

6.1.2 *Supply Air System*—A controllable dry air supply or exhaust system designed to provide conditioned air flow through the test specimen at constant pressure and temperature

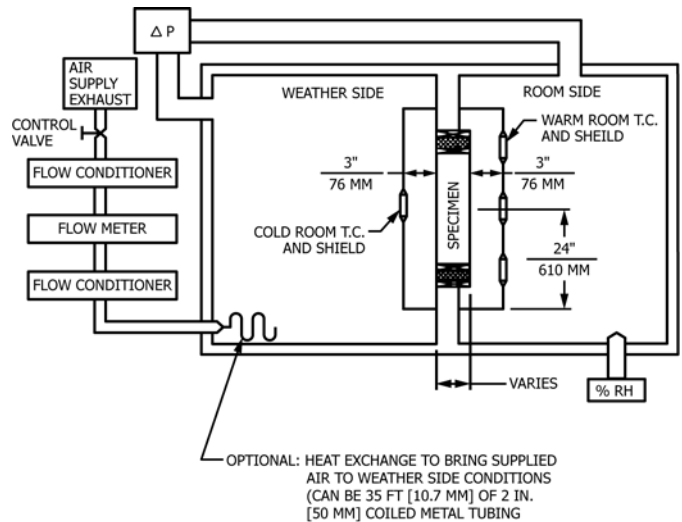

NOTE: AIR FLOW AND METERING SYSTEM MAY BE SET-UP ON THE ROOM SIDE FOR POSITIVE OR NEGATIVE PRESSURE LEAKING MEASUREMENTS.

FIG. 1 Environmental Chamber, Schematic

conditions for sufficient time to obtain required pressure and air flow readings. The system shall be designed to eliminate pressure fluctuations during the air flow measurements. This may be accomplished through the use of a heat exchanger system connected to the air supply port inside of the weathering portion of the test apparatus (see Fig. 1).

6.1.3 *Air Temperature Conditioning System*—A system to maintain weather-side and room-side air test temperatures to within $\pm 1^{\circ}\text{C}$ (2°F) of setpoint. The system shall consist of heating and refrigeration equipment designed to maintain the required test temperatures for extended periods of time. A means of dehumidification shall be available to control the room-side relative humidity levels to the limits recommended in Table 1.

6.1.4 *Pressure Measuring Apparatus*—A device to measure the differential test pressures to $\pm 2\%$ of setpoint or ± 2.5 Pa (± 0.01 in. of water column), whichever is greater.

6.1.5 *Air Flow Metering System*—A device to measure the air flow into the test chamber or through the test specimen. The air flow measurement error shall not exceed $\pm 5\%$ when the air flow equals or exceeds 9.44×10^{-4} m³/s (2 ft³/min) or $\pm 10\%$ when the air flow is less than 9.44×10^{-4} m³/s (2 ft³/min).

NOTE 1—At lower flows, a greater percentage of errors will be acceptable. Special flow metering techniques are necessary if higher precision is required. The accuracy of the specimen air leakage flow measurement is affected by the accuracy of the flowmeter and the amount of extraneous air leakage (see Annex A1).

6.1.6 *Air Temperature Measuring System*—Temperature sensing devices (TSD) such as thermocouples, RTDS, etc., suspended in air, surrounded by shields to reduce radiative heat transfer effects, as shown in Fig. 2. The thermocouples shall be located at the intersection of the vertical and horizontal centerlines of the test specimen. The air TSD shall be movable to maintain a distance of 76 ± 8 mm (3 ± 0.3 in.) measured perpendicular to the outermost plane of the test specimen. The ambient air and surface temperature measuring and indicating instrumentation shall have resolution of 1°C or 1°F and precision of $\pm 1^{\circ}\text{C}$ ($\pm 2^{\circ}\text{F}$).

6.1.7 *Humidity Control System*—Instrumentation to measure and control the room-side humidity. The system shall have resolution to 1% RH and shall have precision to $\pm 3\%$ of setpoint.

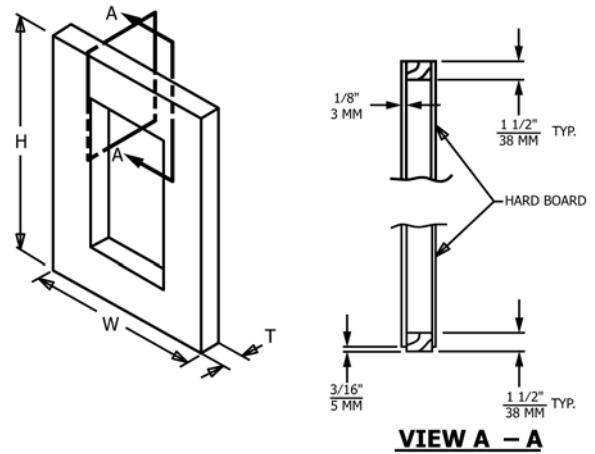

FIG. 2 Test Specimen Mask Detail

7. Hazards

7.1 Glass breakage may occur at the test pressure differences applied in this test. Adequate precautions should be taken to protect personnel.

7.2 The interior walls of the weather-side compartment as well as other surfaces within this compartment may be dangerous to the exposed skin of testing personnel when extreme elevated or depressed test temperature conditions are in effect. Proper care and precautions should be taken to prevent injuries.

8. Test Specimen

8.1 The specimen is the entire assembled unit submitted for testing as described in this section.

8.2 The test specimen for a wall shall be of sufficient size to determine the performance of all typical parts of the wall system. For curtain walls or walls constructed with prefabricated units, the specimen width shall be not less than two typical units plus the connections and supporting elements at both sides, and sufficient to provide full loading on at least one typical vertical joint or framing member, or both. The height shall be not less than the full building story height or the height of the unit, whichever is greater, and shall include at least one full horizontal joint, accommodating vertical expansion, with such joint being at or near the bottom of the specimen, as well as all connections at the top and bottom of the units.

8.2.1 All parts of the wall test specimen shall be full size, using the same materials, details, and methods of construction and anchorage as used on the actual building.

8.2.2 Conditions of structural support shall be simulated as accurately as possible.

8.3 The test specimen for a window, door, or other component shall consist of the entire assembled unit, including frame and anchorage as supplied by the manufacturer for installation in the building. If only one specimen is to be tested, the selection shall be determined by the specifying authority.

NOTE 2—The air leakage rate is likely to be a function of size and geometry of the specimen.

TABLE 1 Recommended Maximum Room-Side Humidity Levels for Glass Specimens—Natural Convection, Indoor Air at 23.3°C (74°F)^A

Outdoor Temperature, °C (°F)	Single Glazing, RH, %	Double Glazing, RH, %
4.4 (40)	39	59
-1.1 (30)	29	50
-6.7 (20)	21	43
-12.2 (10)	15	36
-17.8 (0)	10	30
-23.3 (-10)	7	26
-28.9 (-20)	5	21
-34.4 (-30)	3	17

^A Reference: 1983 ASHRAE EQUIPMENT MANUAL, p. 5.